

NDR as used in research

Bendix Carstensen Steno Diabetes Center
Gentofte, Denmark
<http://BendixCarstensen.com>

SDC, 14 April 2016

<http://BendixCarstensen.com/DMreg/NDR>

Basic demographic concepts

- ▶ **Prevalence** — how many persons are alive with diabetes at a given date.
Often taken as a proportion

Basic demographic concepts

- ▶ **Prevalence** — how many persons are alive with diabetes at a given date.
Often taken as a proportion
- ▶ **Incidence** — how many new cases occur.
A rate, new cases per 1000 persons per year, say.

Basic demographic concepts

- ▶ **Prevalence** — how many persons are alive with diabetes at a given date.
Often taken as a proportion
- ▶ **Incidence** — how many new cases occur.
A rate, new cases per 1000 persons per year, say.
- ▶ **Mortality** — how many persons with diabetes die.
A rate, deaths per 1000 persons with diabetes per year, say.

Basic demographic concepts — requirements

- ▶ **Date** of event (inclusion in register):

Basic demographic concepts — requirements

- ▶ **Date** of event (inclusion in register):
 - ▶ specific dates:

Basic demographic concepts — requirements

- ▶ **Date** of event (inclusion in register):
 - ▶ specific dates:
 - ▶ date in LPR

Basic demographic concepts — requirements

- ▶ **Date** of event (inclusion in register):
 - ▶ specific dates:
 - ▶ date in LPR
 - ▶ date of insulin purchase

Basic demographic concepts — requirements

- ▶ **Date** of event (inclusion in register):
 - ▶ specific dates:
 - ▶ date in LPR
 - ▶ date of insulin purchase
 - ▶ ...

Basic demographic concepts — requirements

- ▶ **Date** of event (inclusion in register):
 - ▶ specific dates:
 - ▶ date in LPR
 - ▶ date of insulin purchase
 - ▶ ...
- ▶ **Constancy** of persons in the register

Basic demographic concepts — requirements

- ▶ **Date** of event (inclusion in register):
 - ▶ specific dates:
 - ▶ date in LPR
 - ▶ date of insulin purchase
 - ▶ ...
- ▶ **Constancy** of persons in the register
- ▶ **Date** of exit (cure and/or death)

Basic demographic concepts — requirements

- ▶ **Date** of event (inclusion in register):
 - ▶ specific dates:
 - ▶ date in LPR
 - ▶ date of insulin purchase
 - ▶ ...
- ▶ **Constancy** of persons in the register
- ▶ **Date** of exit (cure and/or death)
- ▶ **Date of birth**

Basic demographic concepts — requirements

- ▶ **Date** of event (inclusion in register):
 - ▶ specific dates:
 - ▶ date in LPR
 - ▶ date of insulin purchase
 - ▶ ...
- ▶ **Constancy** of persons in the register
- ▶ **Date** of exit (cure and/or death)
- ▶ **Date of birth**
- ▶ for research: linkage by **person identifier**.

Changes in prevalence 1995–2012

- ▶ For each date 1 Jan 1995, 1 Jan 1996, . . . , 1 Jan 2012:

Changes in prevalence 1995–2012

- ▶ For each date 1 Jan 1995, 1 Jan 1996, . . . , 1 Jan 2012:
- ▶ Who is alive with diabetes on the date

Changes in prevalence 1995–2012

- ▶ For each date 1 Jan 1995, 1 Jan 1996, . . . , 1 Jan 2012:
- ▶ Who is alive with diabetes on the date
- ▶ Classify by sex and age

Changes in prevalence 1995–2012

- ▶ For each date 1 Jan 1995, 1 Jan 1996, . . . , 1 Jan 2012:
- ▶ Who is alive with diabetes on the date
- ▶ Classify by sex and age
- ▶ Compare to population figures from Statistics Denmark

Changes in prevalence 1995–2012

- ▶ For each date 1 Jan 1995, 1 Jan 1996, . . . , 1 Jan 2012:
- ▶ Who is alive with diabetes on the date
- ▶ Classify by sex and age
- ▶ Compare to population figures from Statistics Denmark
- ▶ \Rightarrow what percent in each age has diabetes on each date?

Changes in prevalence 1995–2012

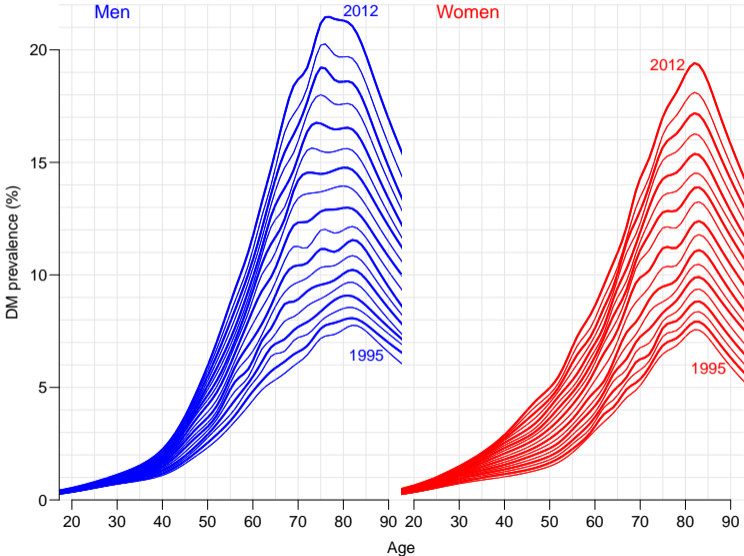

Changes in prevalence 1995–2012 (no glucose crit.)

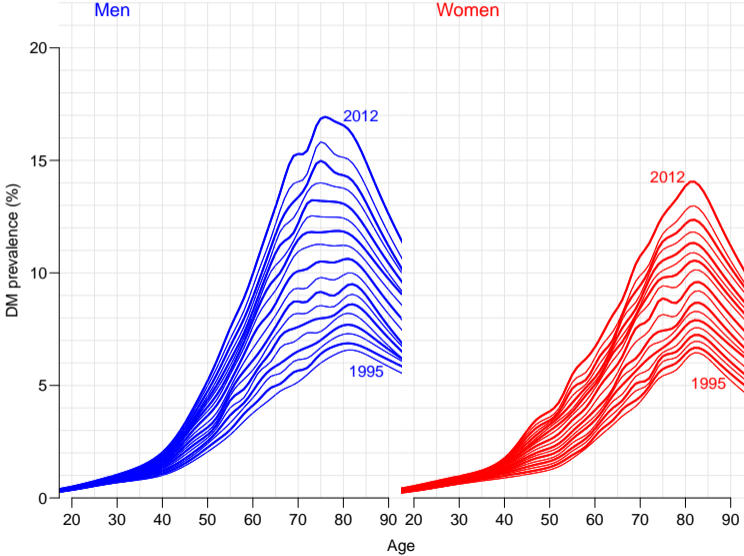

Demographic scenario

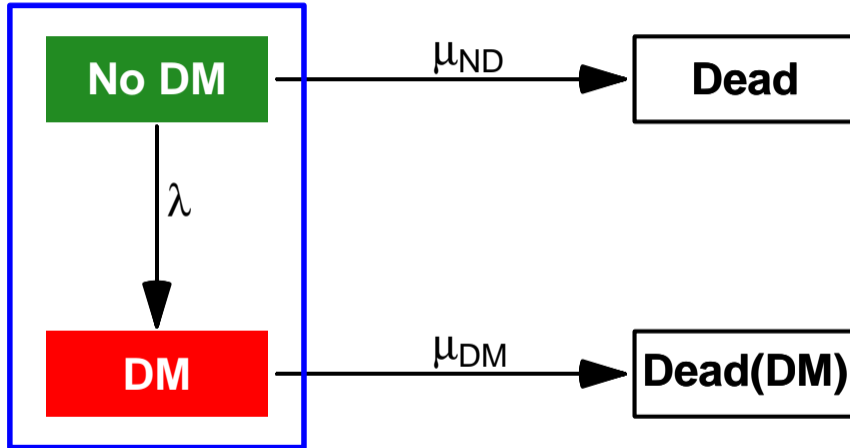

Demographic scenario

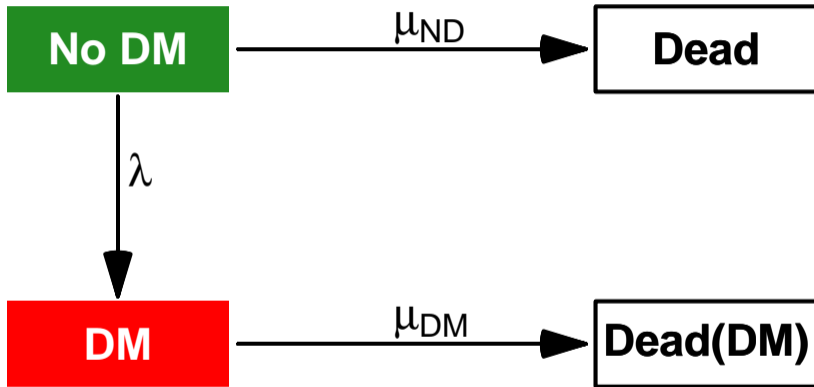

Mortality and years of life lost

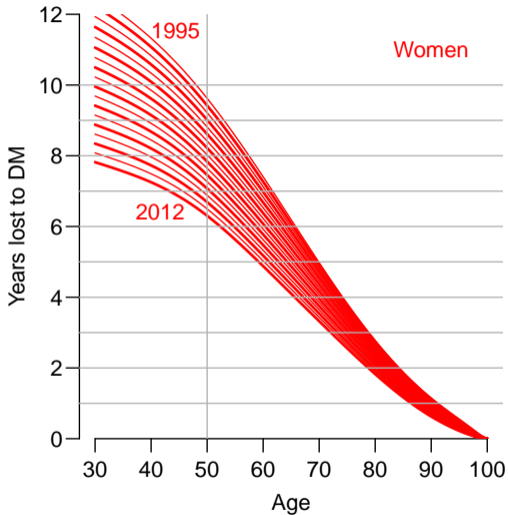
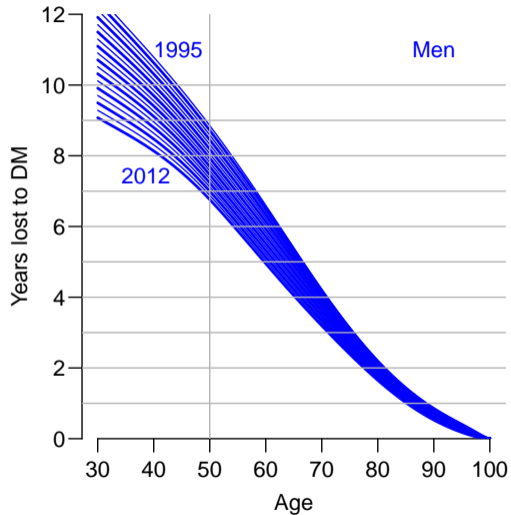

Mortality and years of life lost

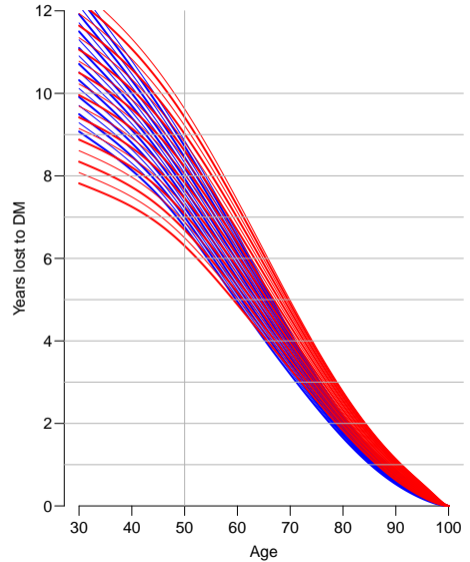

Cancer in diabetes patients

- ▶ Does cancer occur more among persons with diabetes?

Cancer in diabetes patients

- ▶ Does cancer occur more among persons with diabetes?
- ▶ Linkage with Danish Cancer Register

Cancer in diabetes patients

- ▶ Does cancer occur more among persons with diabetes?
- ▶ Linkage with Danish Cancer Register
- ▶ Population data from Statistics Denmark

Cancer in diabetes patients

- ▶ Does cancer occur more among persons with diabetes?
- ▶ Linkage with Danish Cancer Register
- ▶ Population data from Statistics Denmark
- ▶ → cancer incidence in persons with diabetes

Cancer in diabetes patients

- ▶ Does cancer occur more among persons with diabetes?
- ▶ Linkage with Danish Cancer Register
- ▶ Population data from Statistics Denmark
- ▶ → cancer incidence in persons with diabetes
- ▶ → cancer incidence in persons without diabetes

Cancer in diabetes patients

- ▶ Does cancer occur more among persons with diabetes?
- ▶ Linkage with Danish Cancer Register
- ▶ Population data from Statistics Denmark
- ▶ → cancer incidence in persons with diabetes
- ▶ → cancer incidence in persons without diabetes
- ▶ Compare by the hazard ratio

Cancer in diabetes patients

- ▶ Does cancer occur more among persons with diabetes?
- ▶ Linkage with Danish Cancer Register
- ▶ Population data from Statistics Denmark
- ▶ → cancer incidence in persons with diabetes
- ▶ → cancer incidence in persons without diabetes
- ▶ Compare by the hazard ratio
- ▶ All DM vs Non-DM: **1.21**

Cancer in diabetes patients

- ▶ Does cancer occur more among persons with diabetes?
- ▶ Linkage with Danish Cancer Register
- ▶ Population data from Statistics Denmark
- ▶ → cancer incidence in persons with diabetes
- ▶ → cancer incidence in persons without diabetes
- ▶ Compare by the hazard ratio
- ▶ All DM vs Non-DM: **1.21**
- ▶ DM-no-ins vs Non-DM: **1.18**

Cancer in diabetes patients

- ▶ Does cancer occur more among persons with diabetes?
- ▶ Linkage with Danish Cancer Register
- ▶ Population data from Statistics Denmark
- ▶ → cancer incidence in persons with diabetes
- ▶ → cancer incidence in persons without diabetes
- ▶ Compare by the hazard ratio
- ▶ All DM vs Non-DM: **1.21**
- ▶ DM-no-ins vs Non-DM: **1.18**
- ▶ DM-ins vs Non-DM: **1.40**

Cancer in diabetes patients

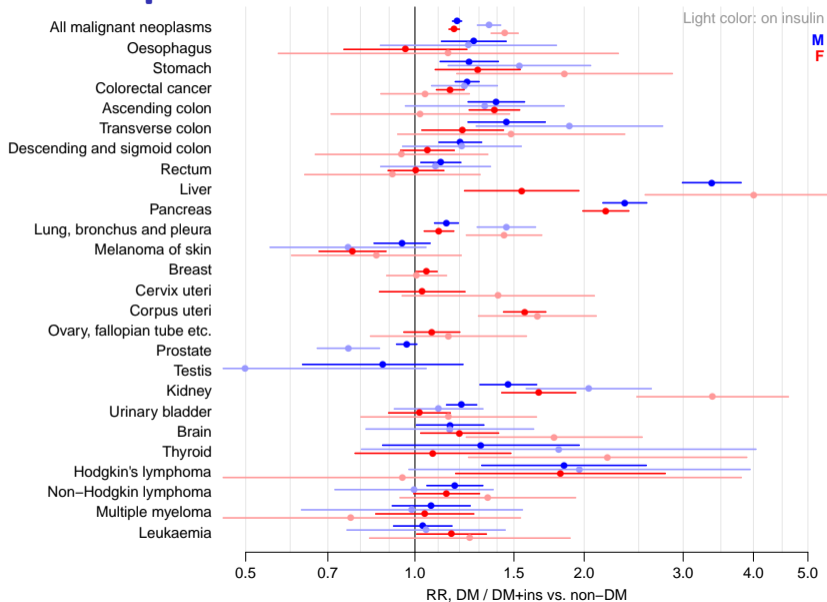

Cancer in diabetes patients

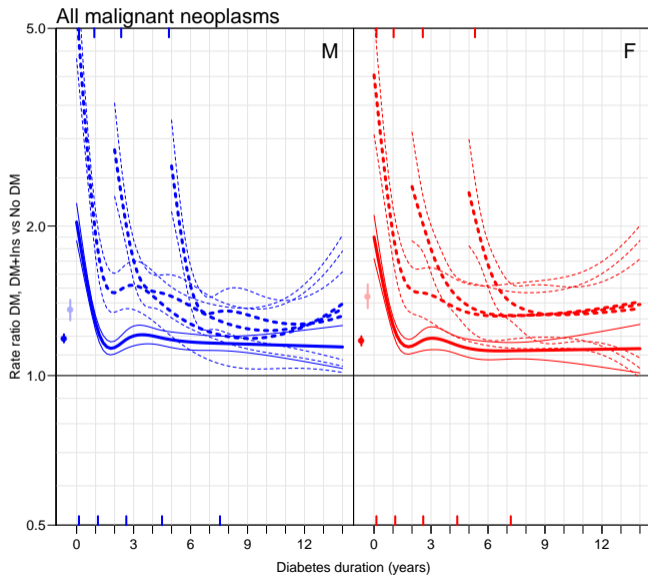

Cancer in diabetes patients

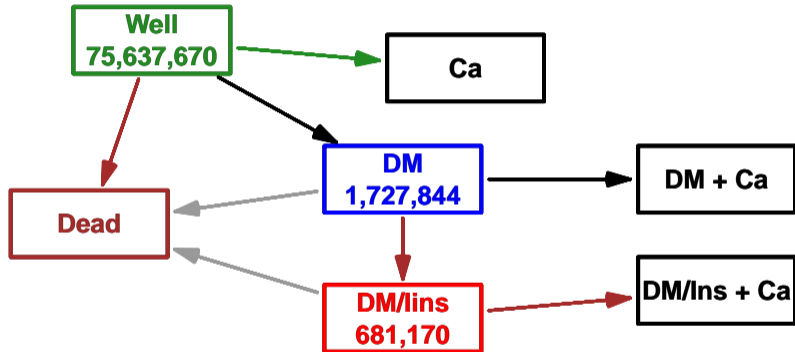

Cancer in diabetes patients

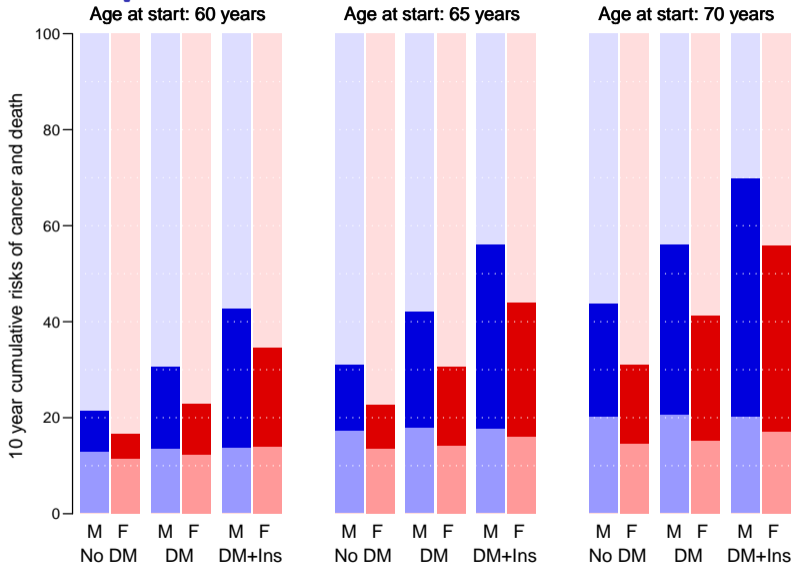

Diabetes register in research — requirements

- ▶ Entry well well defined

Diabetes register in research — requirements

- ▶ Entry well well defined
- ▶ Entry criteria well defined **at entry**

Diabetes register in research — requirements

- ▶ Entry well well defined
- ▶ Entry criteria well defined **at entry**
- ▶ Exit criteria well defined (death, cure?)

Diabetes register in research — requirements

- ▶ Entry well well defined
- ▶ Entry criteria well defined **at entry**
- ▶ Exit criteria well defined (death, cure?)
- ▶ All dates recorded at individual level

Diabetes register in research — requirements

- ▶ Entry well well defined
- ▶ Entry criteria well defined **at entry**
- ▶ Exit criteria well defined (death, cure?)
- ▶ All dates recorded at individual level
- ▶ Linkage possibilities essential

Diabetes register in research — requirements

- ▶ Entry well well defined
- ▶ Entry criteria well defined **at entry**
- ▶ Exit criteria well defined (death, cure?)
- ▶ All dates recorded at individual level
- ▶ Linkage possibilities essential
- ▶ ⇒ detailed medical (DM) history of persons

Diabetes register in research — requirements

- ▶ Entry well well defined
- ▶ Entry criteria well defined **at entry**
- ▶ Exit criteria well defined (death, cure?)
- ▶ All dates recorded at individual level
- ▶ Linkage possibilities essential
- ▶ ⇒ detailed medical (DM) history of persons

Diabetes register in research — requirements

- ▶ Entry well well defined
- ▶ Entry criteria well defined **at entry**
- ▶ Exit criteria well defined (death, cure?)
- ▶ All dates recorded at individual level
- ▶ Linkage possibilities essential
- ▶ ⇒ detailed medical (DM) history of persons

These are the **essential** requirements for research and surveillance at the population level

Diabetes register in clinical research

- ▶ Include clinical **history** of patients

Diabetes register in clinical research

- ▶ Include clinical **history** of patients
- ▶ ... e.g. annual updates on clinical measurements

Diabetes register in clinical research

- ▶ Include clinical **history** of patients
- ▶ ... *e.g.* annual updates on clinical measurements
- ▶ monitor clinical course of patients

Diabetes register in clinical research

- ▶ Include clinical **history** of patients
- ▶ ... *e.g.* annual updates on clinical measurements
- ▶ monitor clinical course of patients
- ▶ monitor clinical determinants of complications

Diabetes register in clinical research

- ▶ Include clinical **history** of patients
- ▶ ... *e.g.* annual updates on clinical measurements
- ▶ monitor clinical course of patients
- ▶ monitor clinical determinants of complications
- ▶ ... and death

Diabetes register in clinical research

- ▶ Include clinical **history** of patients
- ▶ ... *e.g.* annual updates on clinical measurements
- ▶ monitor clinical course of patients
- ▶ monitor clinical determinants of complications
- ▶ ... and death

Diabetes register in clinical research

- ▶ Include clinical **history** of patients
- ▶ ... e.g. annual updates on clinical measurements
- ▶ monitor clinical course of patients
- ▶ monitor clinical determinants of complications
- ▶ ... and death

These are the **desirable** requirements for a diabetes register usable directly in clinical research.

Diabetes register in clinical research

- ▶ Include clinical **history** of patients
- ▶ ... e.g. annual updates on clinical measurements
- ▶ monitor clinical course of patients
- ▶ monitor clinical determinants of complications
- ▶ ... and death

These are the **desirable** requirements for a diabetes register usable directly in clinical research.

Tak for opmærksomheden